

STEREO PREAMPLIFIER

C-21

OPERATING INSTRUCTIONS

KU

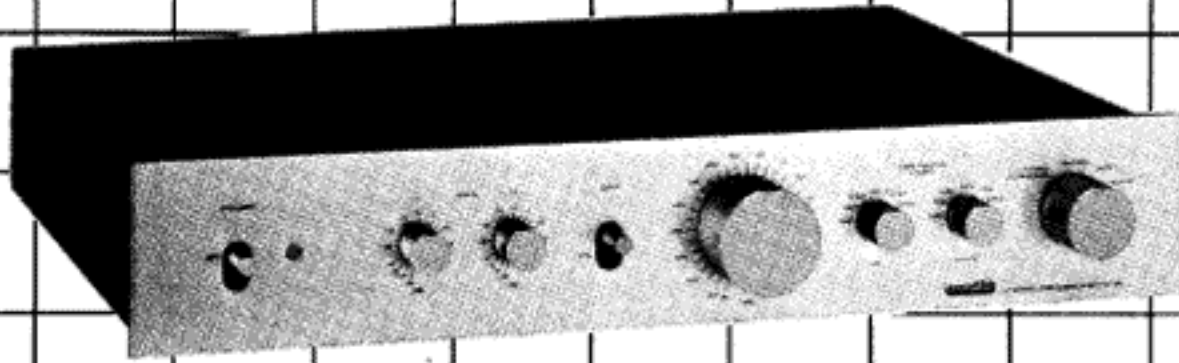

IMPORTANT NOTICE

The serial number for this equipment is located on the rear panel. Please write this serial number on your enclosed warranty card and keep in a secure area. This is for your security.

series20[®]

WARNING: TO PREVENT FIRE OR SHOCK HAZARD, DO NOT EXPOSE THIS APPLIANCE TO RAIN OR MOISTURE.

CONTENTS

The C-21 is a stereo preamplifier composed of an equalizer amplifier and a flat amplifier and designed to display the ultimate in sound quality. It is a streamlined model and so does not feature a tone control circuit or accessory circuitry. Please read this instruction manual through carefully before using your C-21 so that you derive the most from your program sources in reproduction fidelity.

Features	2
Configuration of the Stereo System	3
Installation Precautions	3
Connection Diagram	4
Connections	5
Names and Uses of the Controls	6
Before Listening to a Program Source	7
Operation	7
Using the Tape Decks	8
Other Applications	9
Characteristics Charts	11
Specifications	12

FEATURES

Equalizer Circuit for Faithful Record Reproduction

The equalizer amplifier consists of a differential amplifier which employs low-noise p-n-p transistors for the first stage, and another differential amplifier with a current mirror circuit for the second stage. Together, they improve the efficiency of the line voltage and the linearity. The output stage is a Class-A pure complementary SEPP circuit which provides a broad dynamic range and a low output impedance. This circuit eliminates distortion, even with high-output cartridges and high peak input music sources, and it features a smooth combination with the next stage. Ultra-precision metal film resistors (0.5% error) and polypropylene capacitors (1% error) with excellent temperature characteristics are used in combination as the equalizer elements and they keep the deviation down to between 20Hz and 20kHz (± 0.2 dB).

The phono circuit is provided with a subsonic filter which attenuates frequencies less than 15Hz by 6dB/oct. This ensures that ultra-low-frequency noise, intermodulation distortion and factors which might damage the speakers are all eliminated.

Flat Amplifier with Excellent Frequency Response

The flat amplifier incorporates a differential amplifier for the first stage, a differential amplifier with a current mirror circuit for the second stage, and the output stage is a Class-A pure complementary SEPP circuit. Its configuration is practically identical to that of the equalizer amplifier and so it too displays a broad dynamic range and an unbeatable frequency response. It improves the S/N ratio, distortion and other characteristics without a tone control circuit or filter circuitry.

Phono Circuit with Selectable Input Resistance and Input Capacitance

The phono input circuit provides the optimum input resistance and capacitance, according to the characteristics of the cartridge. There are selector switches for the input resistance (100/10k/25k/50k/75k/100k ohms) and for the load capacitance (100/150/200/300/400/500pF). These switches allow you to select load impedances and load capacitances other than those specified, even if you have just the one cartridge, and so you can enjoy subtle changes in the sound quality. The CARTRIDGE LOAD impedance switch has a 100ohm setting which permits the S/N ratio to be further improved for more enjoyable record reproduction when you use a high-output moving coil cartridge.

Highly Dependable Volume Control

The volume control features an attenuator with 32 different settings. It is extremely reliable and so you can adjust the volume accurately. Also included are two gain controls which can be used to adjust the C-21's output levels for both channels within a ± 6 dB range, according to the input sensitivity of the power amplifier.

Attractive and Practical Design

All the controls are mounted on the front panel. The controls are very easy to handle and the switches respond lightly to the touch. The panel itself has a slim design.

All in all, this is a new preamplifier which opens up a new dimension in sound. As such, it is a pioneer among hi-fi components.

CONFIGURATION OF THE STEREO SYSTEM

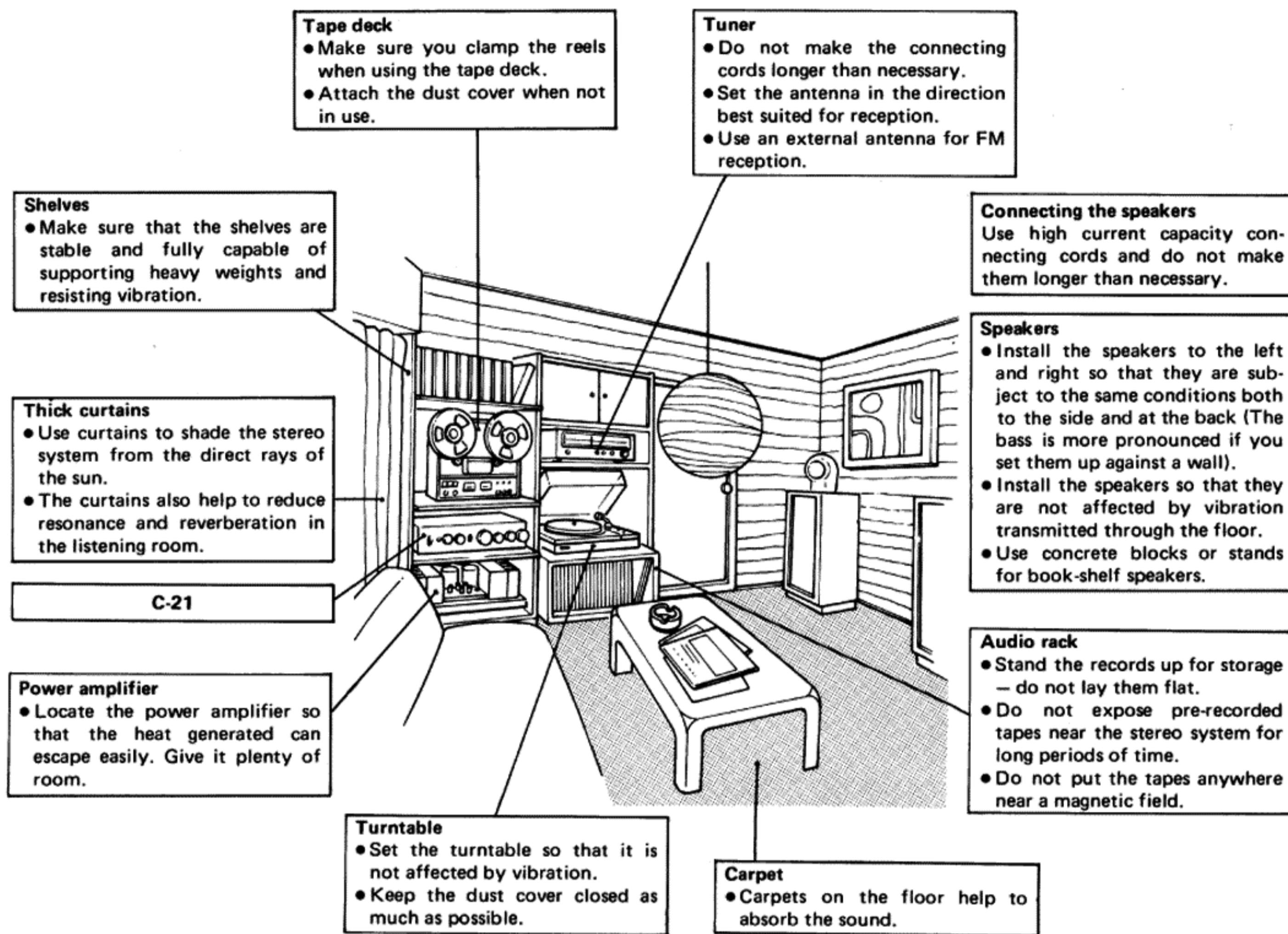

INSTALLATION PRECAUTIONS

You should avoid installing your hi-fi components in the locations outlined below. Proper installation will ensure a long service life.

Locations to be avoided	Possible trouble
1 Locations exposed to direct rays of the sun, or close to heating appliances or any heat-generating products.	1 External heat downgrades the performance of the circuit parts and prohibits stable operation.
2 Locations which are exposed to a great deal of dust, moisture or humidity, or poorly ventilated locations.	2 These locations may cause defective input/output terminal contact and corrosion. In particular, humidity and moisture easily give rise to defects in the insulation. There is also the danger of current leakage and heat generated by the circuit parts.
3 Locations which are not flat and which are susceptible to vibration.	3 Hi-fi components are heavy and therefore are a potential danger in an earthquake. These locations also exert an adverse effect on the precision parts.
4 Locations close to sources of alcohol, insecticides and other inflammables.	4 These items corrode the outer panel.

CONNECTION DIAGRAM

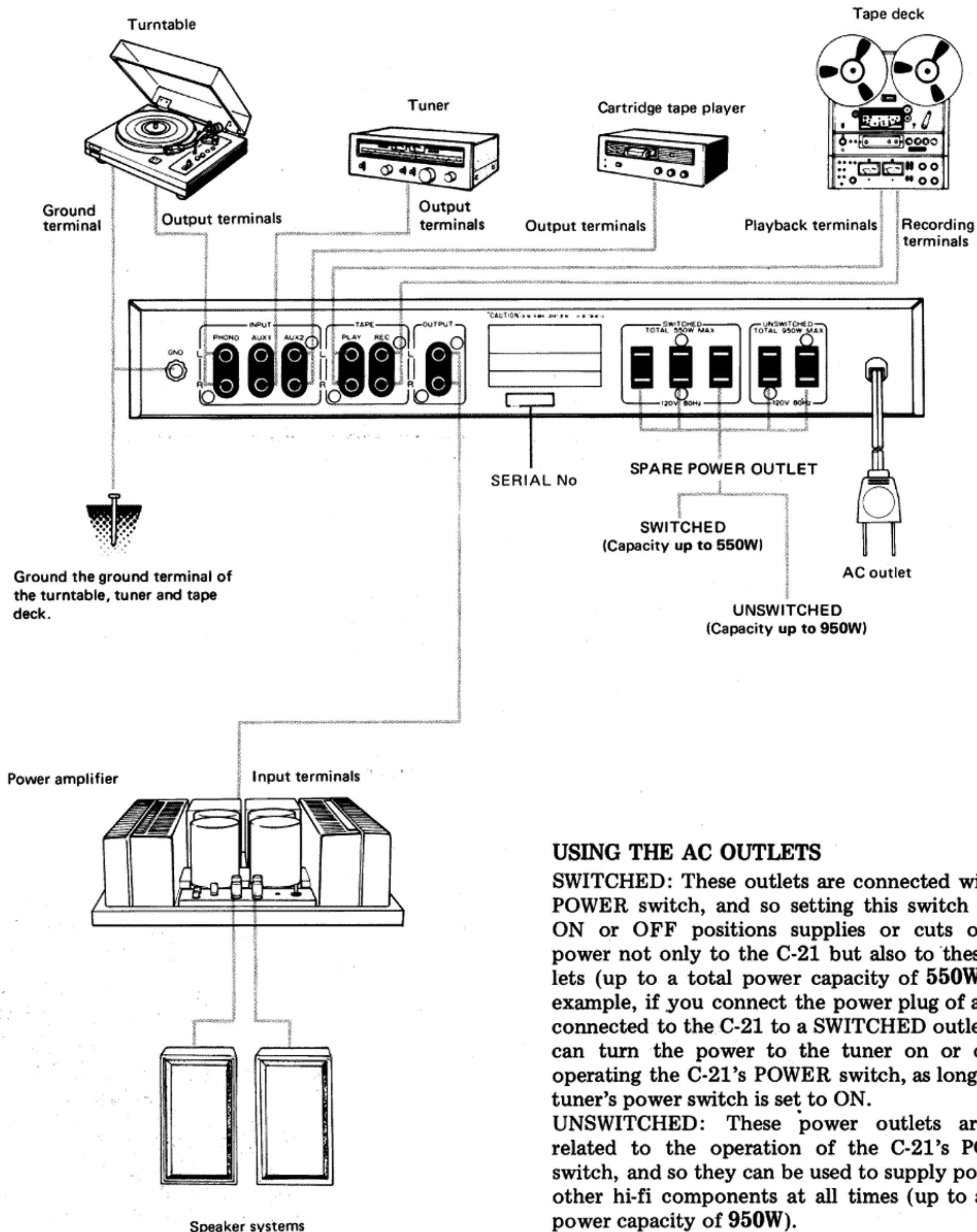

USING THE AC OUTLETS

SWITCHED: These outlets are connected with the POWER switch, and so setting this switch to the ON or OFF positions supplies or cuts off the power not only to the C-21 but also to these outlets (up to a total power capacity of 550W). For example, if you connect the power plug of a tuner connected to the C-21 to a SWITCHED outlet, you can turn the power to the tuner on or off by operating the C-21's POWER switch, as long as the tuner's power switch is set to ON.

UNSWITCHED: These power outlets are not related to the operation of the C-21's POWER switch, and so they can be used to supply power to other hi-fi components at all times (up to a total power capacity of 950W).

CONNECTIONS

POWER AMPLIFIER

As shown in Fig. 1, connect the power amplifier's input terminals to the C-21's OUTPUT terminals using the accessory connecting cords.

The upper terminal is for the L (left) channel and the lower terminal is for the R (right) channel.

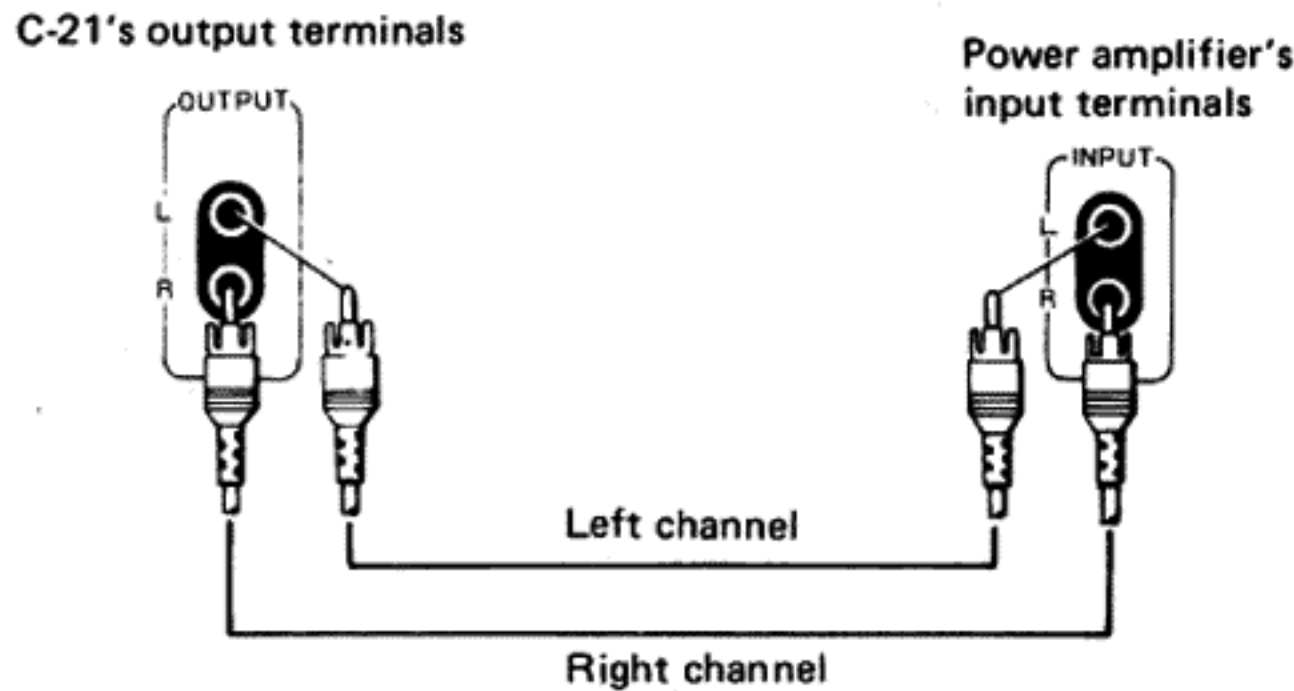

Fig. 1

TURNTABLE

Connect the turntable's output terminals to the C-21's PHONO terminals and connect the turntable's ground wire to the GND terminal (see Fig. 2).

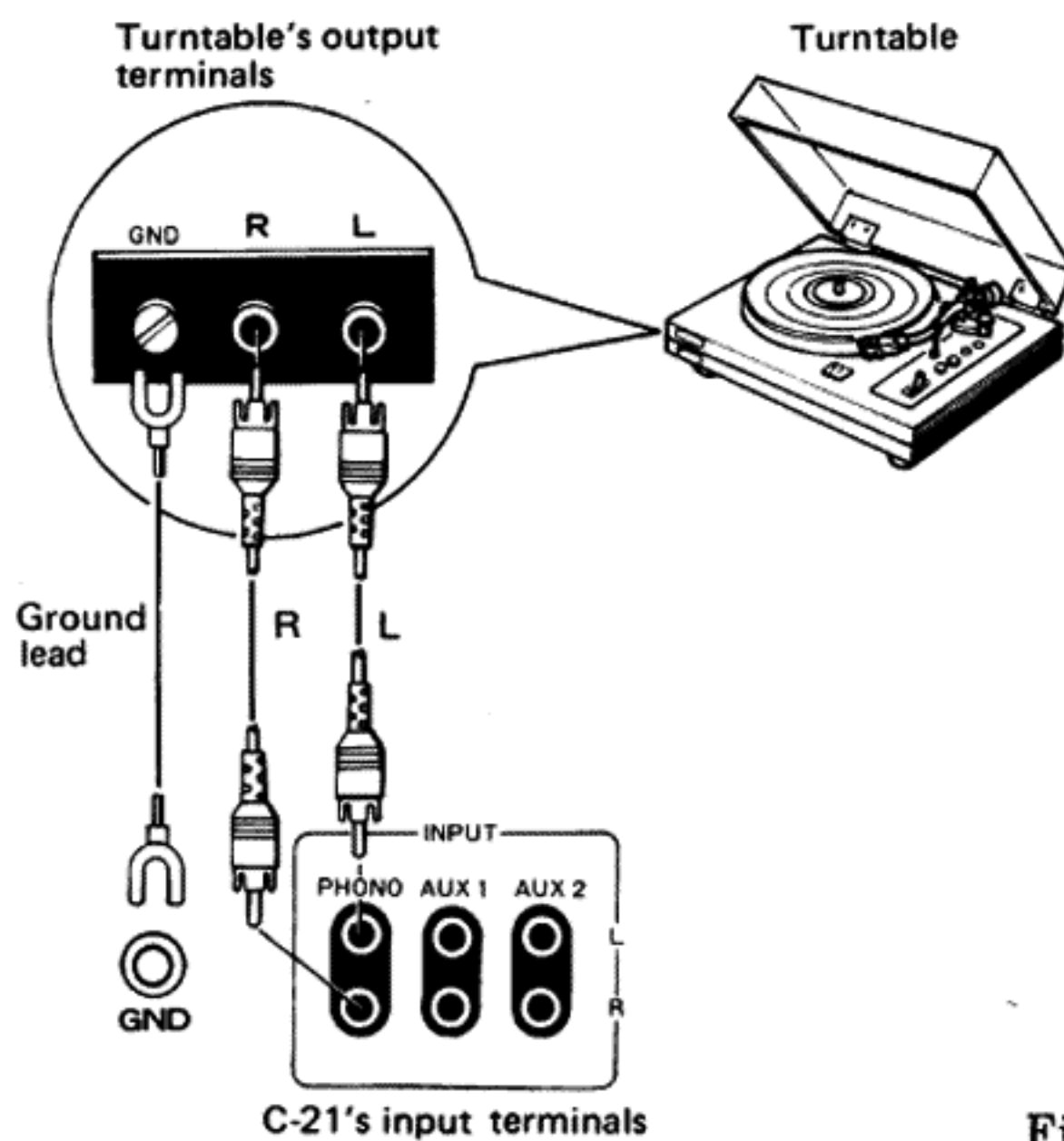

Fig. 2

NOTES:

1. Use either a moving magnet (MM), induced magnet (IM) or a high-output moving coil (MC) cartridge for your turntable. If you intend to use a low-output moving coil (MC) cartridge, make sure you use a special matching transformer or a head amplifier designed only for MC cartridges.
2. You can select the input impedance on the C-21 according to the load capacitance and the load impedance specified by the cartridge. Just operate the CARTRIDGE LOAD switches. Refer to page 7 for the operation instructions.

AUX 1, 2 TERMINALS

These are spare input terminals (see Fig. 3).

You can use them to connect a stereo tuner, cartridge tape player, a TV tuner output or even the playback output of a second tape deck.

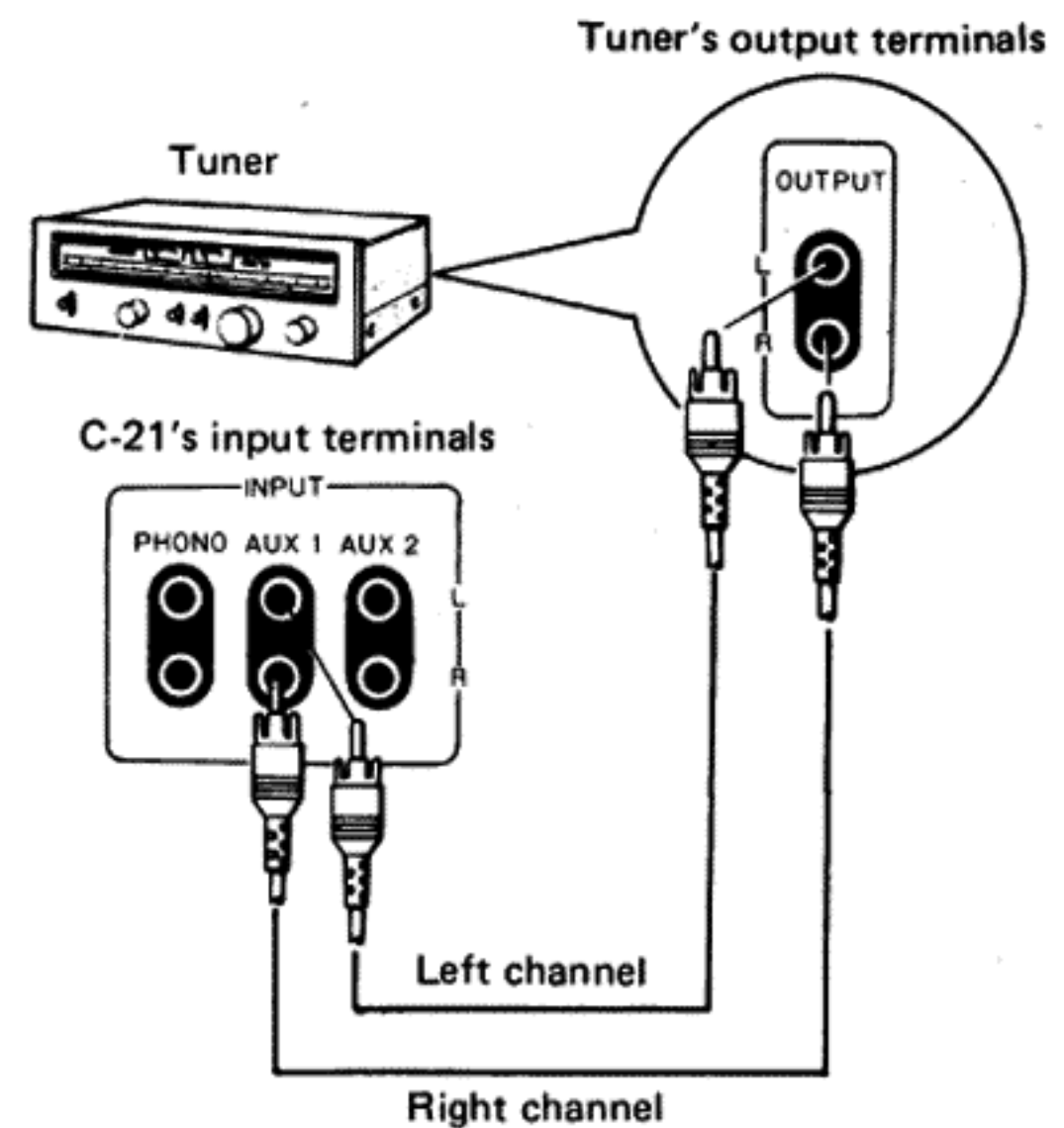

Fig. 3

CONNECTION PRECAUTIONS

- Make sure that you connect the inputs and outputs of the components, which are connected to the C-21, to the same channels (L to L, R to R). The C-21's upper terminals are for the L (left) channel and the lower terminals are for the R (right) channel.
- Make sure that the connections are secure. If the terminals are connected improperly, this may generate noise and impair the sound.

NAMES AND USES OF THE CONTROLS

POWER SWITCH

Set this switch to the ON position and power is supplied to the C-21.

There will be no sound for a brief interval after you have set this switch to ON. This does not indicate a breakdown and it is due to the actuation of the built-in muting circuit.

TAPE SWITCH

Set this switch to the ON position to monitor the playback or recording sound when a tape deck is connected to the C-21's TAPE (REC, PLAY) terminals.

NOTE:

Set this switch to OFF (top setting) when listening to a record or a broadcast program.

VOLUME CONTROL

Use this control to adjust the output level of the OUTPUT terminals.

The dial indicates the attenuation in dB units when the maximum output level is set to 0dB. No sound will pass through the speakers when this control is set to the ∞ position on the bottom left.

CARTRIDGE LOAD SWITCHES

Use these switches to select the input resistance (ohms) and input capacitance (pF) in accordance with the specified load impedance and load capacitance of the cartridge you are using. For further details, please refer to pages 7, 8.

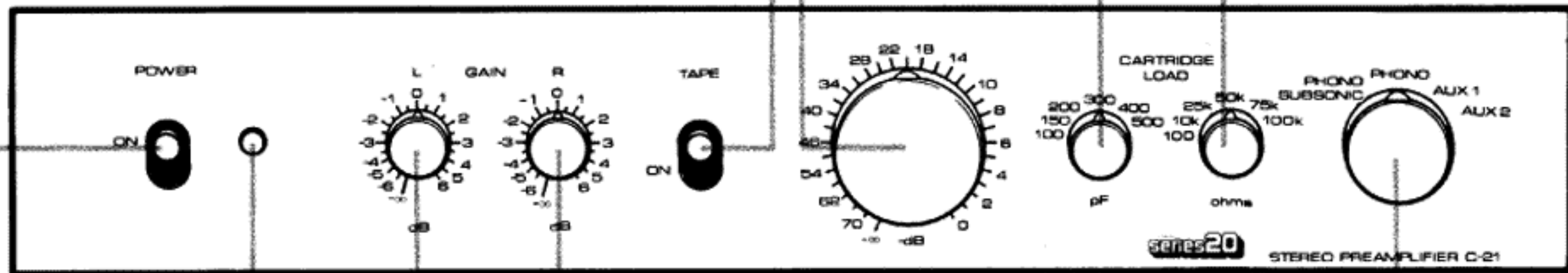

PILOT LAMP

GAIN (L, R) CONTROLS

Adjust these controls in accordance with the input sensitivity of the power amplifier (and speakers, too) connected to the C-21's OUTPUT (L, R) terminals. Output values of 1V, 2V and 0.5V can be obtained when these controls are set to 0dB (center), +6dB and -6dB, respectively, in relation to the rated inputs. When balancing the volume for the left and right channels, turn one of these controls (L or R) either clockwise or counterclockwise and adjust. If the controls are turned to the ∞ position on the bottom left, no sound will pass through the speakers.

FUNCTION SWITCH

Use this switch to select the required program source.

PHONO SUBSONIC: When listening to a record on a turntable connected to the PHONO terminals on the C-21, this switch will actuate the subsonic filter to eliminate low frequency noise caused by warp and other imperfections in the record.

PHONO: Set the switch to this position when listening to a record on a turntable which is connected to the C-21's PHONO terminals.

AUX 1: Set the switch to this position when listening to a program source on a component which is connected to the C-21's AUX 1 terminals.

AUX 2: Set the switch to this position when listening to a program source on a component which is connected to the C-21's AUX 2 terminals.

SUBSONIC FILTER

This filter attenuates frequencies lower than 15Hz by 6dB/oct, and so eliminates ultra-low-frequency noise generated by distortion and other adverse phenomena in records. Although this noise is inaudible, it is a factor which generates intermodulation distortion and can damage the speakers. When listening to records, set the FUNCTION switch to the PHONO SUBSONIC position, and this seemingly harmless noise will be cancelled out.

BEFORE LISTENING TO A PROGRAM SOURCE

BEFORE SUPPLYING POWER TO THE C-21, SET THE FOLLOWING CONTROLS:

1. Set the VOLUME control to ∞ (minimum).
2. Set the TAPE switch to OFF (top setting).
3. Set the GAIN switches in accordance with the input sensitivity of the power amplifier which is connected to the C-21.

POWER AMPLIFIER

1. Connect the power amplifier's power plug to one of the C-21's AC OUTLETS (SWITCHED). Use a wall socket if the power amplifier's power consumption exceeds 550W.
2. Set the POWER switch to ON. (This also supplies power to the power amplifier when the power amplifier's power plug is connected to the C-21's AC outlet (SWITCHED)).

OPERATION

LISTENING TO RECORDS

1. Set the FUNCTION switch to PHONO.
 2. Set the CARTRIDGE LOAD switches according to the specifications of the cartridge you are using. For further details, refer to the section on 'Load resistance and load capacitance'.
 3. Operate the turntable and play the record.
 4. Adjust the VOLUME control to the desired level.
- Set the FUNCTION switch to PHONO SUB-SONIC if a lot of low-frequency noise from the warp and other imperfections in the record is being generated.

POINTS TO NOTE WITH RECORD-PLAYING

Unpleasant noise is sometimes generated while the record is playing so bear in mind the following points:

- Lower the stylus onto the record gently.
- Do not cause the turntable to vibrate while a record is being played since this will cause the stylus to jump and it will scratch or otherwise damage the record.
- Do not switch the turntable's power off while the stylus is still tracing grooves on the record.

USING THE AUX 1 AND 2 TERMINALS

Adopt the following procedure when listening to a program source on a tuner, cartridge tape player (playback only) or TV tuner which is connected to the AUX terminals.

1. When the component is connected to the AUX 1 terminals, set the FUNCTION switch to AUX 1, and when the component is connected to the AUX 2 terminals, set it to AUX 2.
2. Operate the component's controls.
3. Adjust the sound level with the C-21's VOLUME control.

LOAD RESISTANCE AND LOAD CAPACITANCE

As shown in Fig. 4, typical moving magnet (MM) cartridges have resonance peaks at high frequencies. However, the height of the peaks can be varied by changing the load impedance ($R\Omega$). The peaks increase as the impedance is increased. In addition, the resonance frequency (center of peak frequency) can be varied by changing the load capacitance (CpF), as is shown in Fig. 5. If the capacitance is increased then the resonance frequency is lowered and the peaks are increased.

You can vary the load impedance using the C-21's CARTRIDGE LOAD input resistance switch (ohms) and the load capacitance with the CARTRIDGE LOAD input capacitance switch (pF). By using these two switches in combination, you can obtain a number of different high frequency characteristics. Operate the switches as follows:

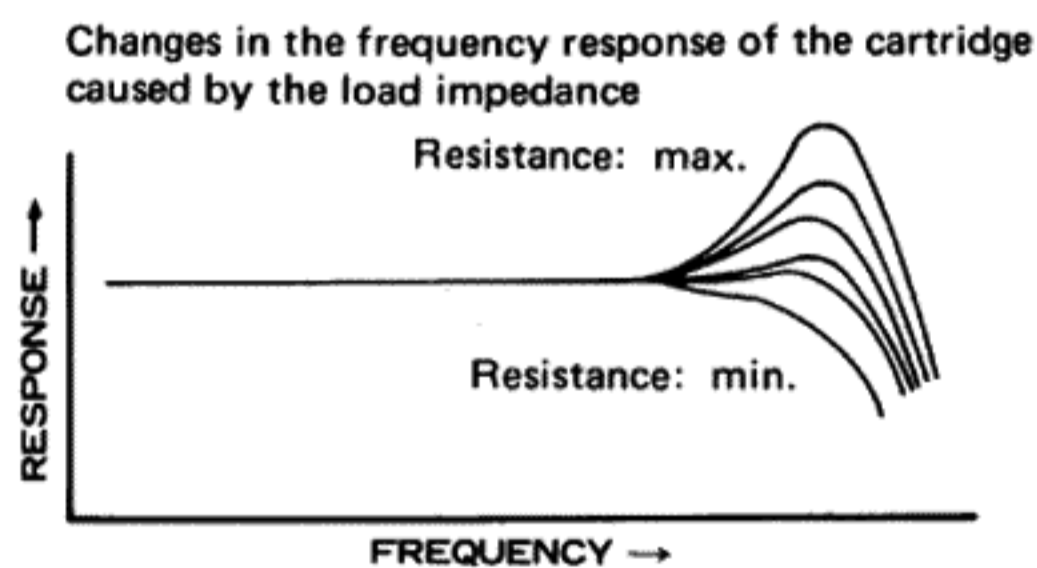

Fig. 4

NOTE:

If you are using a high-output moving coil (MC) cartridge, then you can improve the S/N ratio by setting the input resistance switch to 100 Ω .

When The Cartridge Load Impedance and Load Capacitance are Specified

- Set the input resistance switch (ohms) to the specified load impedance.
- Subtract the turntable's capacitance (stray capacitance of the output cord and tonearm, etc.) from the capacitance specified by the cartridge and select this value with the input capacitance switch (pF).

NOTES:

- Refer to the operating instructions of the cartridge you are using for the specified load impedance and load capacitance.
- Since the turntable capacitance varies with the output cord, wiring and other factors, it is impossible to pinpoint an exact value. However, it is usually in the 100pF–200pF range. Adjust the load capacitance while you are listening to the record.

When Not Specified

One example is shown in Fig. 5 where the frequency response in the high range varies. Adjust both CARTRIDGE LOAD switches while you are listening to the record.

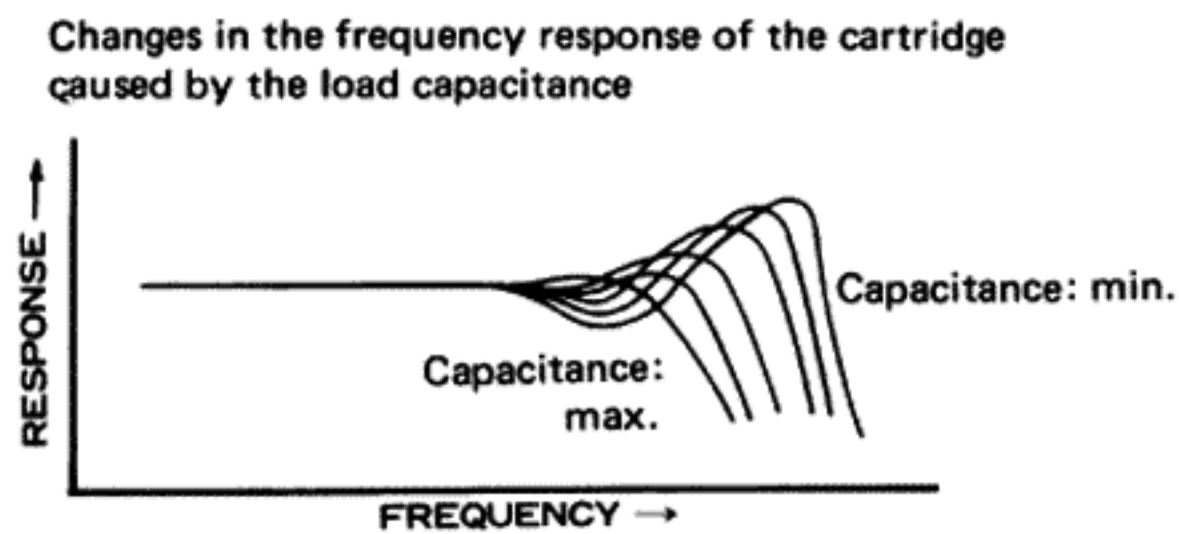

Fig. 5

USING THE TAPE DECKS

CONNECTING THE TAPE DECKS

The C-21 is provided with both TAPE REC and TAPE PLAY terminals. Connect as shown in Fig. 6.

Tape Recording

Use connecting cords to connect the tape deck's LINE INPUT terminals to the C-21's TAPE REC terminals.

Tape Playback

Use the connecting cords to connect the tape deck's LINE OUTPUT terminals to the C-21's TAPE PLAY terminals.

NOTES:

1. The upper terminals are for the L (left) channel and the lower terminals are for the R (right) channel.
2. Use the tape deck's accessory connecting cords for the connections.

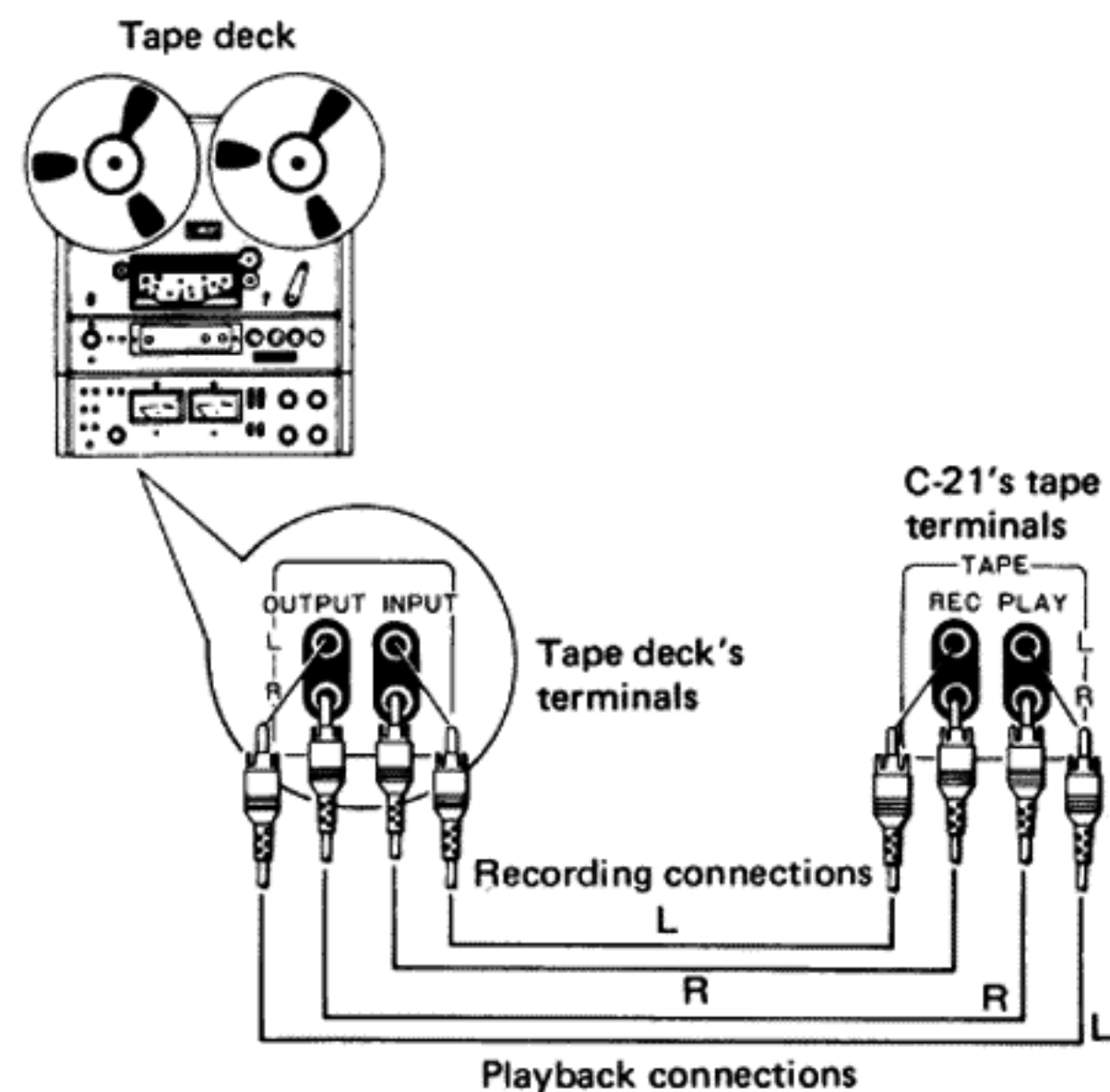

Fig. 6

TAPE PLAYBACK

1. Set the C-21's TAPE switch to ON (Fig. 7).
2. Playback the pre-recorded tape on the tape deck.
3. Adjust the sound level with the VOLUME control.

NOTES:

1. Set the TAPE switch to OFF (top setting) if you are not going to playback the tape.
2. You need not bother about the FUNCTION switch for tape playback since any position will do.

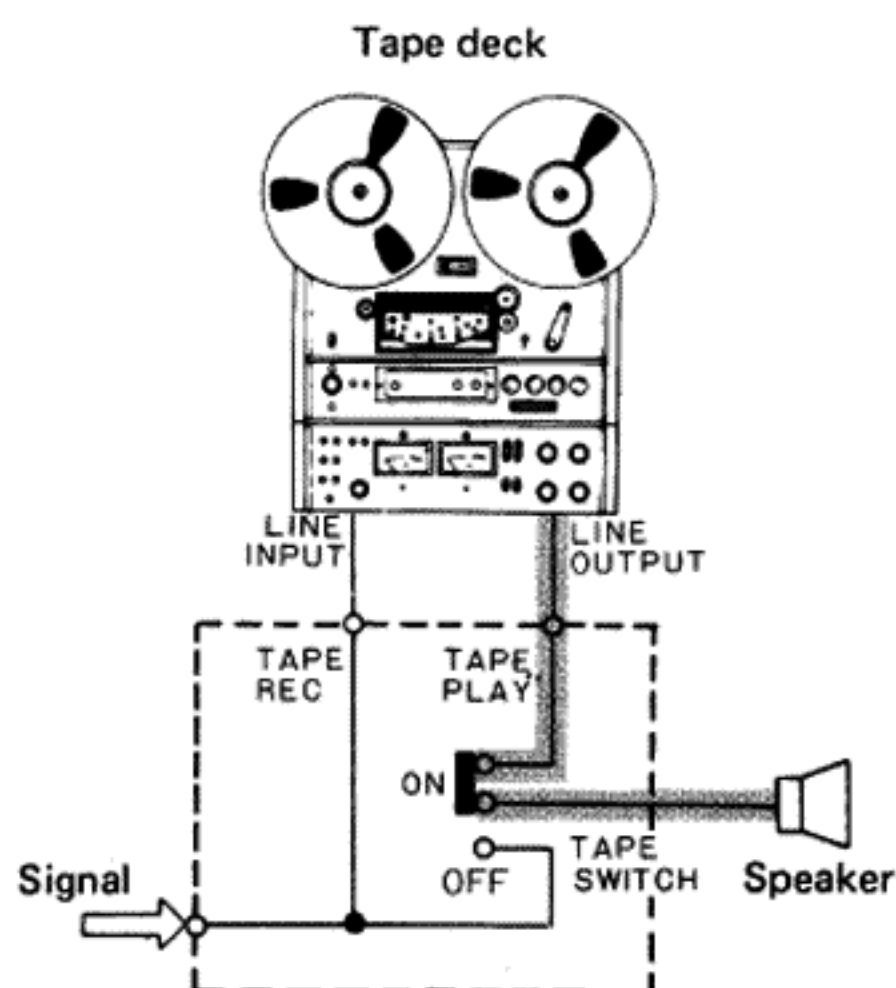

Fig. 7

TAPE RECORDING

1. Set the FUNCTION switch in accordance with the program source (record or FM broadcast) you want to record (Fig. 8).
2. Play the program source.
3. Adjust the recording level using the controls on the tape deck and start recording.

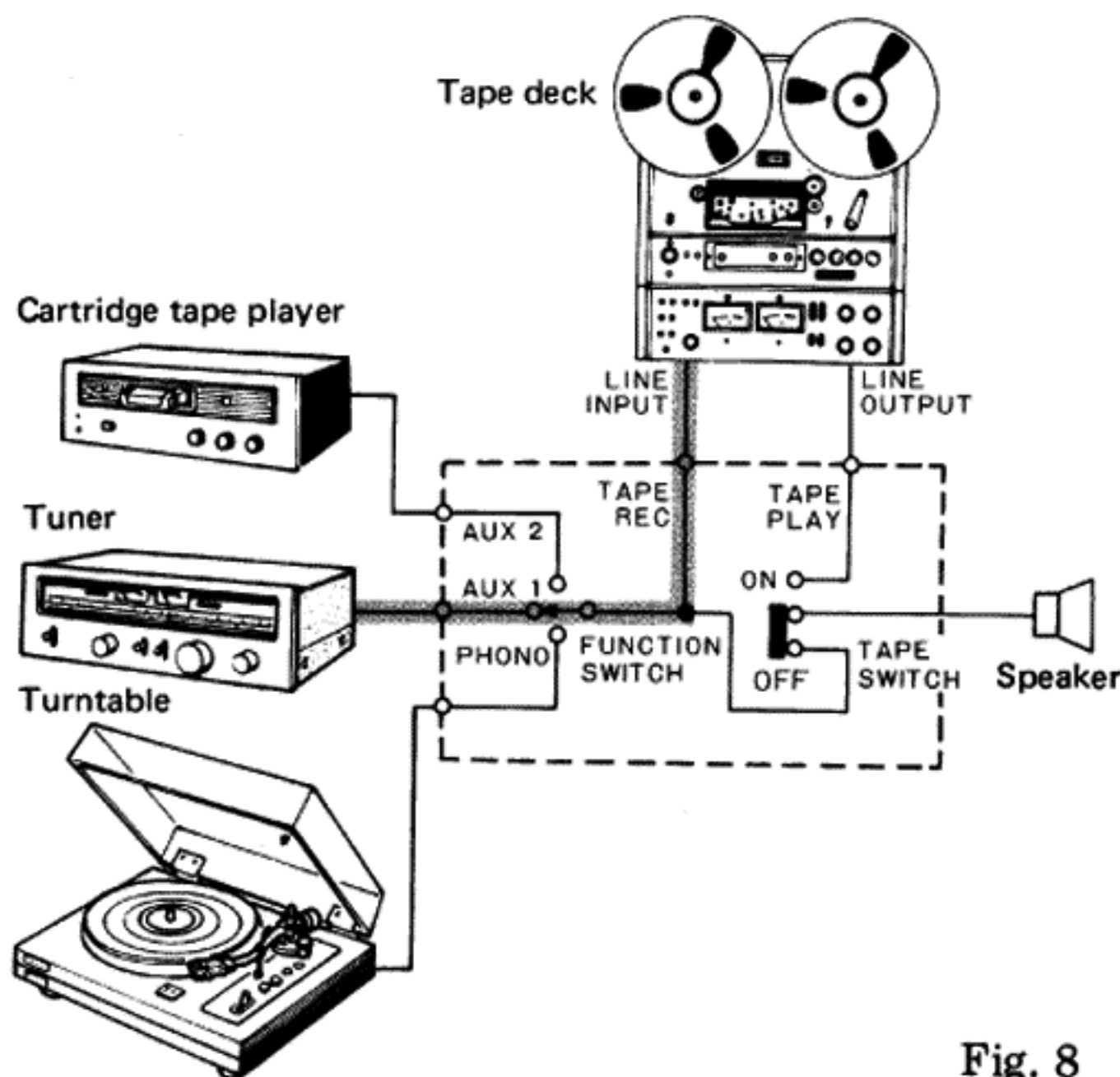

Fig. 8

MONITORING THE RECORDING

When recording a tape with a tape deck (3-head type) having a monitor function, you will be able to check the actual recording on the speakers if you set the TAPE switch to ON. Make sure, however, that you set up the connections for both recording and playback.

OTHER APPLICATIONS

DUPLICATING USING THE AUX TERMINALS

If you have two tape decks, you can duplicate pre-recorded tapes or edit them (refer to Fig. 9). Simply connect the tape deck's LINE OUTPUT terminals to the C-21's AUX 1 (or AUX 2) terminals. You can make use of these applications to build up your own tape library by recording songs or pieces of music which you have pre-recorded from an FM broadcast onto a separate tape and by duplicating tapes from an open-reel deck onto cassette tapes, for example.

1. Connect the two tape decks as illustrated in Fig. 9.
 2. Set the FUNCTION switch to AUX 1 (or 2).
 3. Playback the pre-recorded tape on the tape deck which is connected to the AUX terminals, and record on the tape deck connected to the TAPE terminals.
- If the tape deck you are using to record has a monitoring function (3-head model), you can monitor the recording when you set the C-21's TAPE switch to ON. If the tape deck has only two heads, you will not be able to monitor the recording, but you will be able to monitor the playback sound at the playback end.

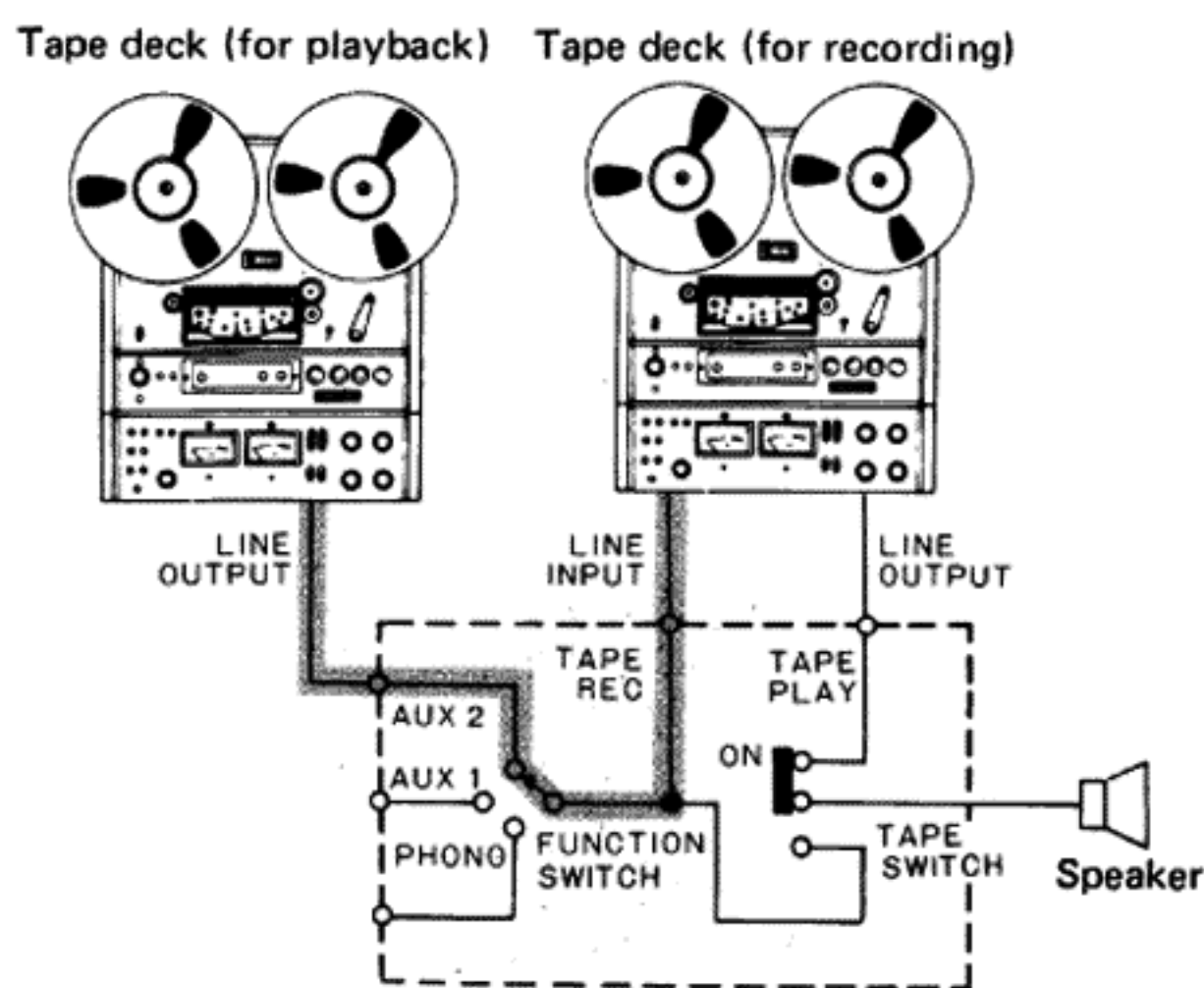

Fig. 9

MULTIPLE AMPLIFIER SYSTEM

As you can see in Fig. 10, a multiple amplifier system can be constructed by adding a crossover network (separate buy) and a stereo power amplifier which drives the various speakers, to the C-21. When the audio frequency is split into two or three sections, the resulting systems are known as a 2-way or 3-way multiple amplifier system, respectively.

You can use Series 20 own electronic crossover network, which is sold separately, to construct the system.

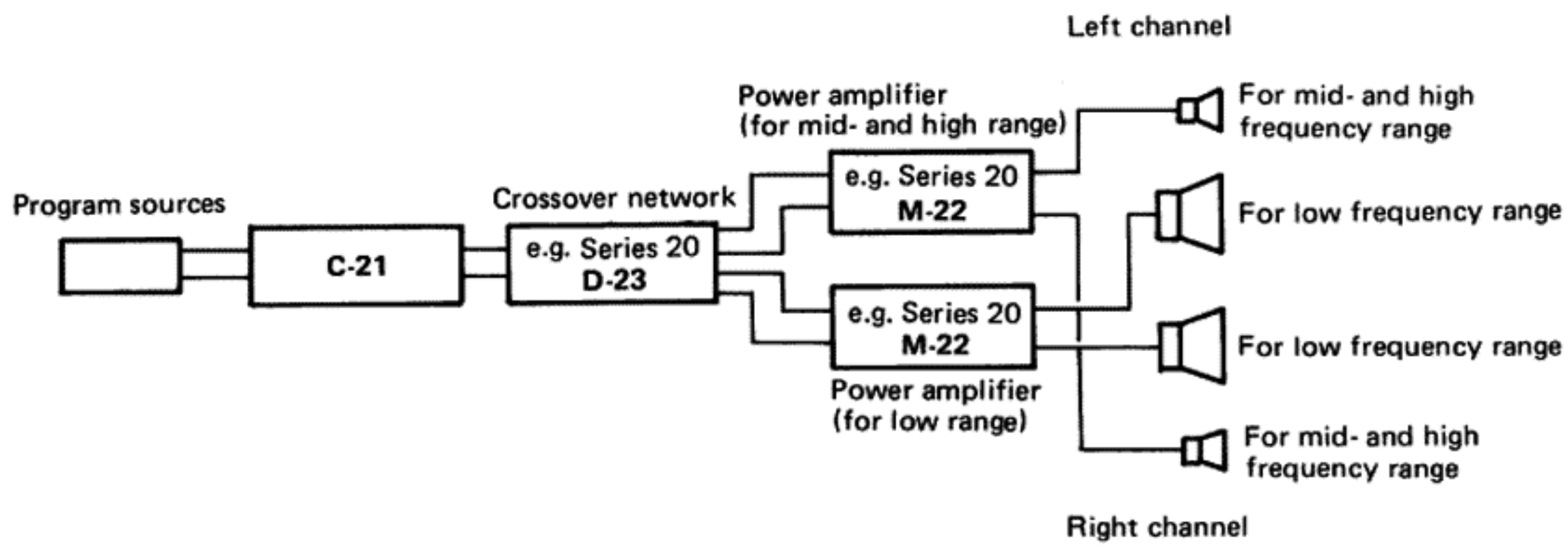

Fig. 10

How to Use the Hexagonal Wrench

If any of the control knobs should happen to come loose, tighten by means of the hexagonal wrench.

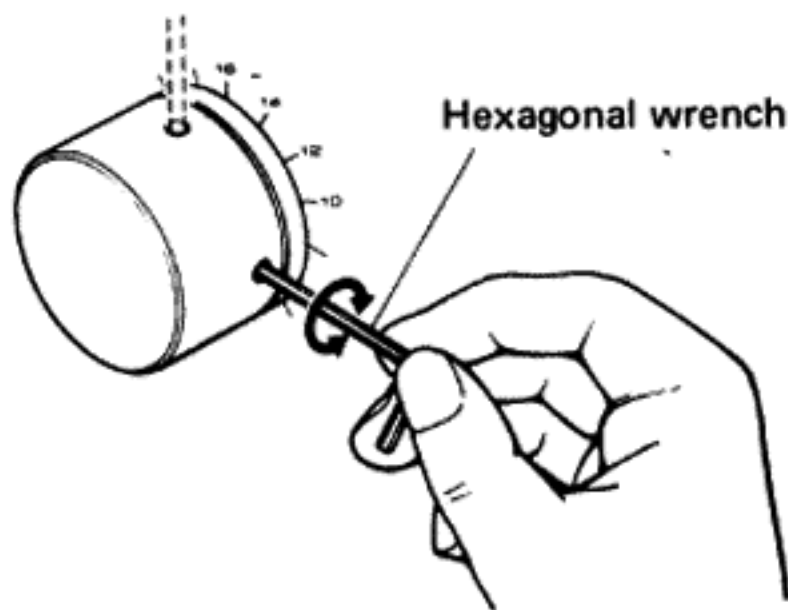
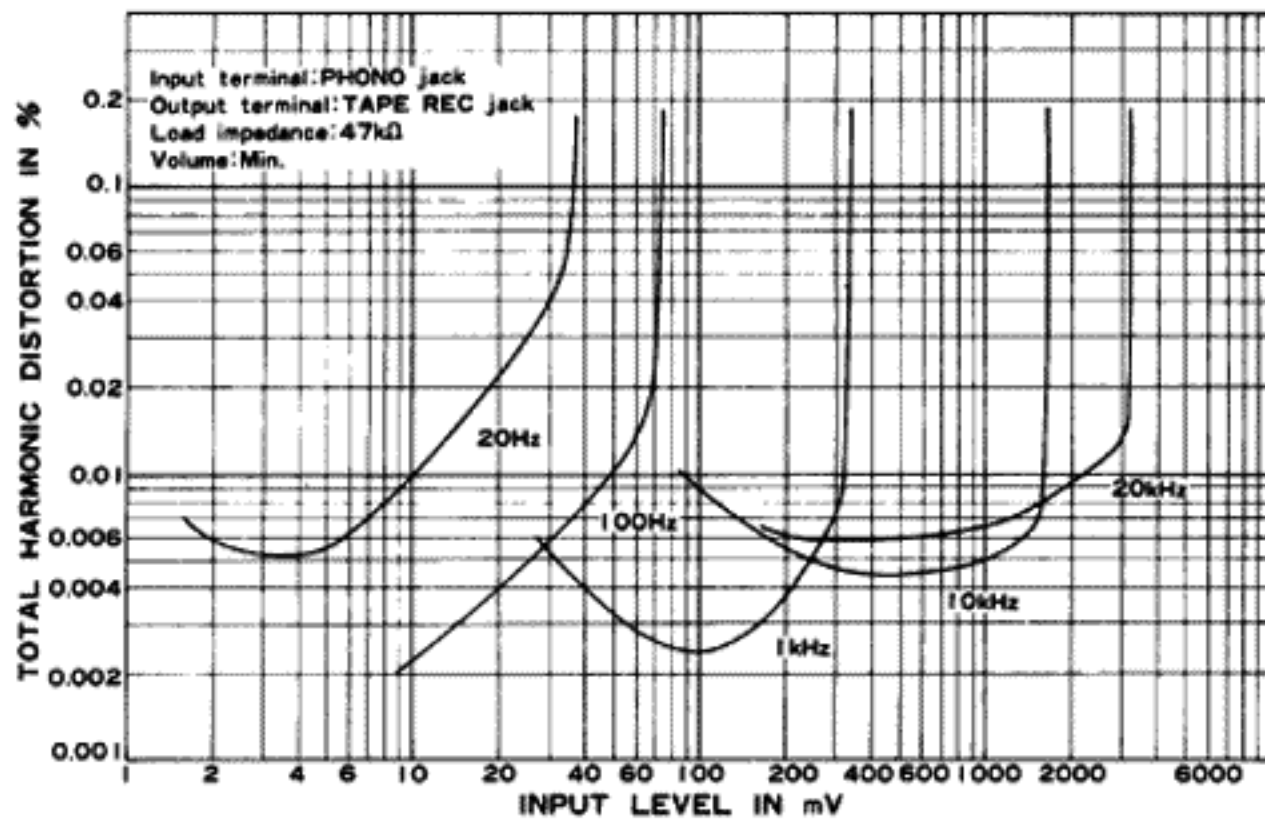

Fig. 11

CHARACTERISTICS CHARTS

■ PHONO INPUT VOLTAGE vs. DISTORTION CHARACTERISTICS



■ AUX OUTPUT VOLTAGE vs. DISTORTION CHARACTERISTICS

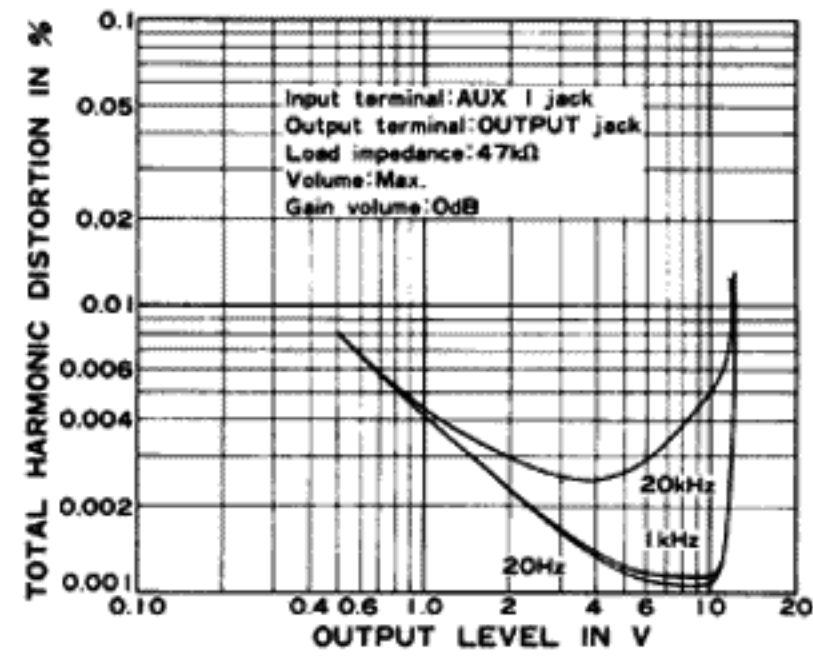

■ PHONO EQUALIZER DEVIATION

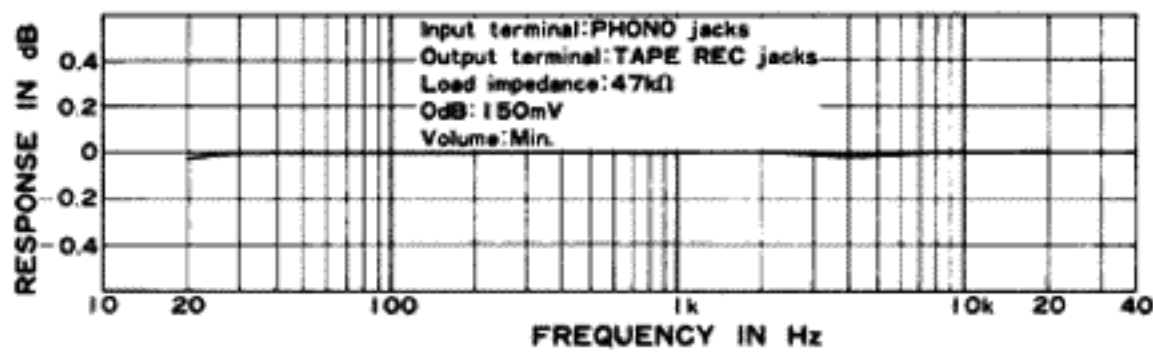

■ FREQUENCY RESPONSE

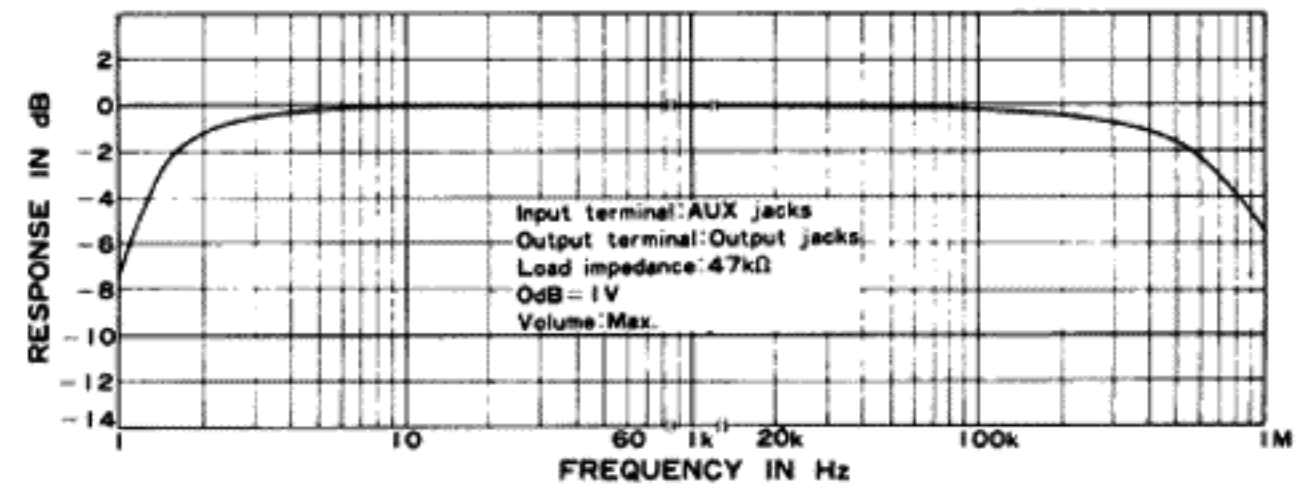

■ PHONO SUBSONIC FILTER CHARACTERISTICS

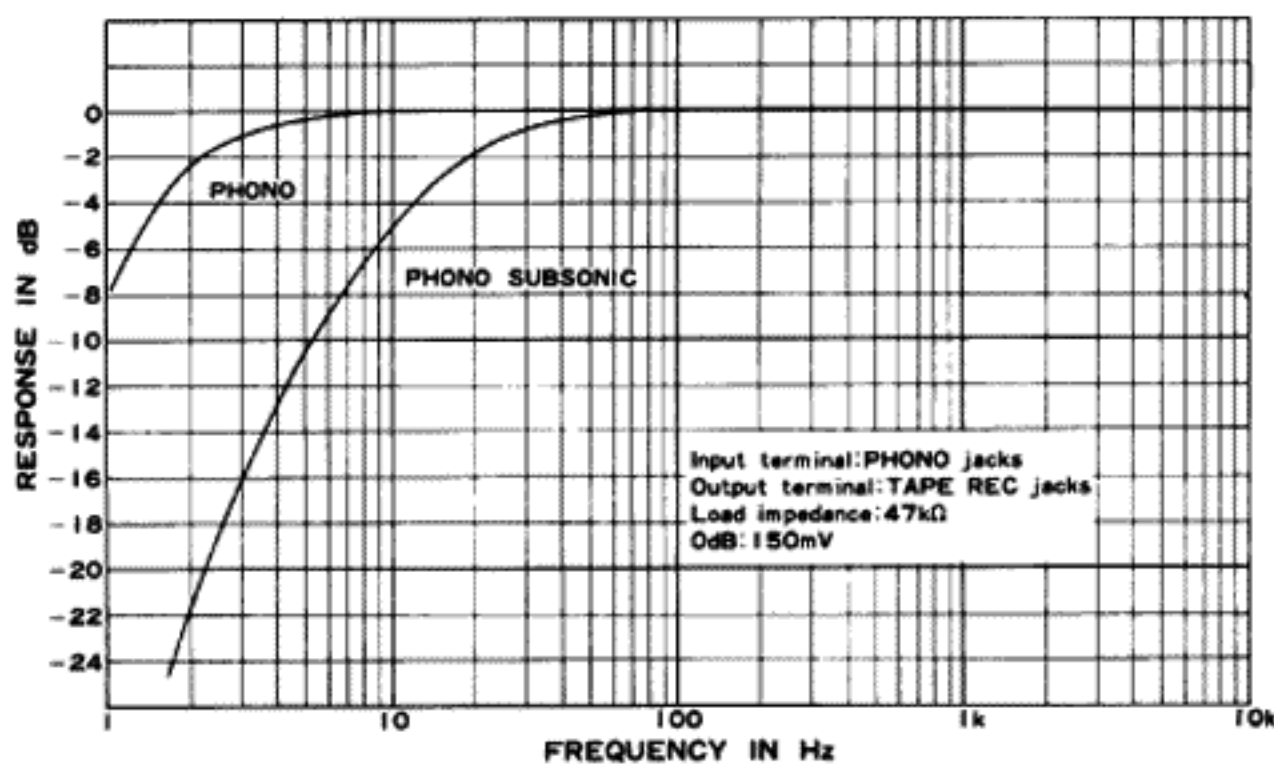

SPECIFICATIONS

Semiconductors

Transistors	36
Diodes	47

Amplifier Section

Circuitry

Equalizer Amplifier	2-stage differential amplifier Class-A SEPP with current mirror circuit
Flat Amplifier	2-stage differential amplifier Class-A SEPP with current mirror circuit

Input (Sensitivity/Impedance)

PHONO	2.5mV/100Ω, 10kΩ, 25kΩ, 50kΩ, 75kΩ, 100kΩ
CARTRIDGE LOAD	100pF, 150pF, 200pF, 300pF, 400pF, 500pF
AUX 1	150mV/50kΩ
AUX 2	150mV/50kΩ
TAPE PLAY	150mV/50kΩ

PHONO Overload Level

(T.H.D.: 0.01%) 300mV (1kHz)

Output (Level/Impedance)

TAPE REC	150mV/1kΩ
OUTPUT (R _L : 50kΩ)	1V/450Ω (rated) 20V/150Ω (max.)

Total Harmonic Distortion (20Hz to 20,000 Hz)

PHONO	0.006% (1V output, VOLUME: -20dB. GAIN CONTROL: 0dB)
-------	--

AUX

GAIN CONTROL	Output Level			
	1V	5V	10V	20V
-6dB	0.003%	0.005%	—	—
0dB	0.005%	0.003%	0.005%	—
6dB	0.008%	0.003%	0.003%	0.005%

Frequency Response

PHONO	20Hz to 20,000Hz ±0.2dB
AUX	10Hz to 100,000Hz ^{+0dB} / _{-0.2dB} 3Hz to 300,000Hz ^{+0dB} / _{-1.0dB}

Hum and Noise (IHF, short-circuited, A network)

PHONO (1V output)	80dB
AUX (1V output)	100dB
Phono Subsonic Filter	15Hz (6dB/oct.)

Miscellaneous

Power Requirements	120V 60Hz only
Power Consumption	14 watts (UL)
Dimensions	420(W) x 81(H) x 357(D) mm 16-9/16 - 3-3/16 - 14-3/8 in.
Weight	without package: 6.3kg (13 lb 14 oz) with package: 7.4kg (16 lb 5 oz)
AC Outlets	3 (SWITCHED) 2 (UNSWITCHED)

Furnished Parts

Connection Cord with Pin Plugs	1
Operating Instructions	1
Hex. Wrench (used for fastening VOLUME knob)	1

NOTE:

Specifications and the design subject to possible modification without notice due to improvements.

SERIES 20[®]

20 Jewell Street
Moonachie, New Jersey 07074